



Green, Eco-friendly, Revolutionary
— AOF Environment Systems

OIL MIST AIR CLEANER



AF series

Dormatec Environment Systems

Breeuwhamer 25
1648 HG De Goorn
The Netherlands
Tel: +31229-542485
Email: info@dormatec.eu
www.air-o-filter.com
www.dormatec.eu



2019.02E1

AIR FILTRATION SYSTEM

AIR-O-FILTER TECHNOLOGY

Till this day, manufacturing facilities are pointed out as being the main source of coolant mist, smoke and various air pollutant emissions. It not only impacts the environment around us, but also represents a threat to public health. With today's collective awareness for sustainable development, we can create a cleaner, safer and greener place for tomorrow. The Air-O-Filter is going to help you in that endeavor. With its easy-to-install design, this system offers a cost-effective and low energy solution for greater working environment, meeting all regulatory and industry standards.

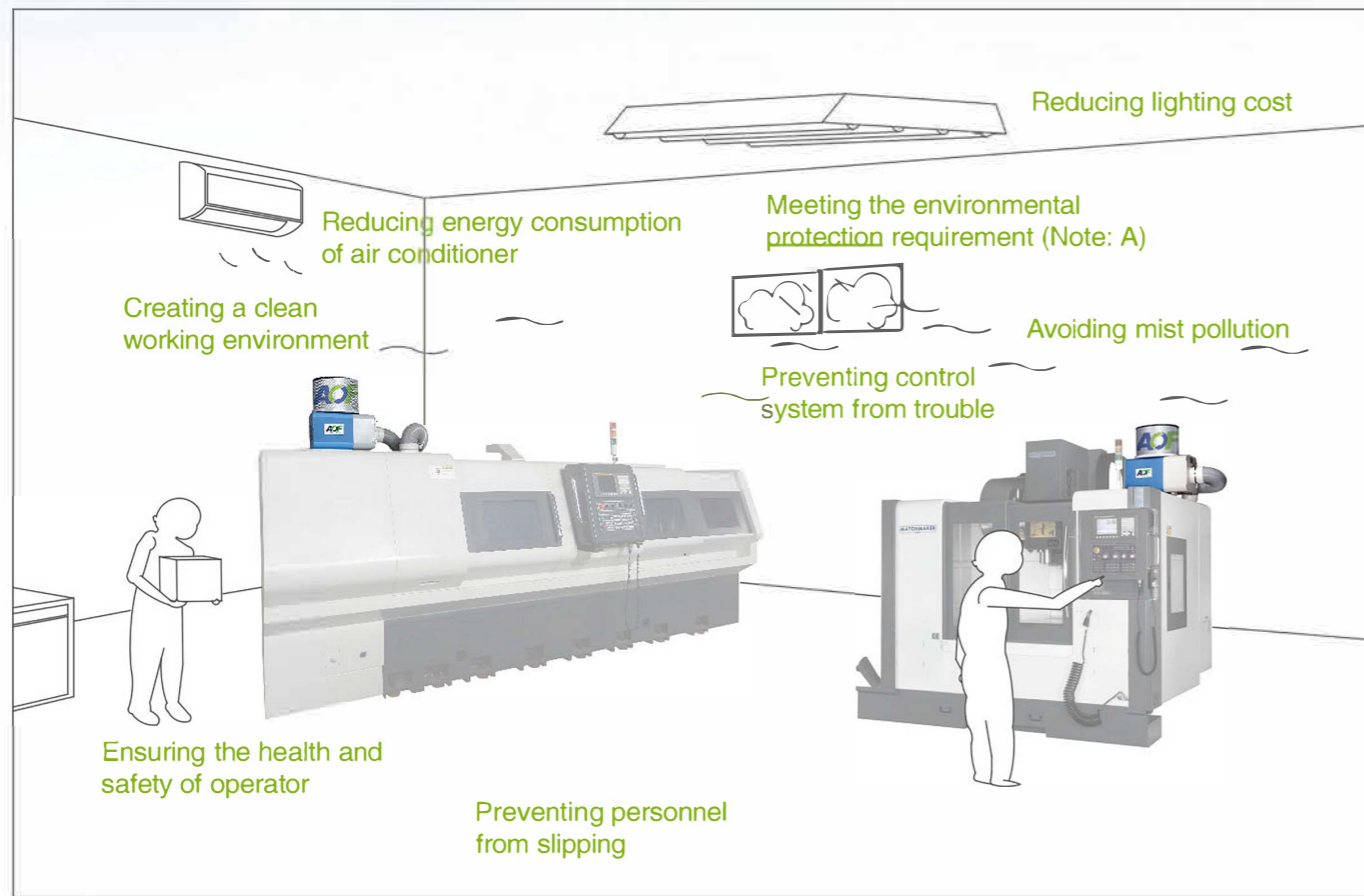

Fine Particulate Matter (PM2.5)

What Is Fine Particulate Matter?

"Fine Particulate matter" consists of fine particles that float in the air with a size less than 2.5 μm (Hereafter called PM2.5).

Where Does Fine Particulate Matter Come From?

PM2.5 particles are created by nature and human behavior. Natural sources include volcanic eruptions and the earth's crust rocks. Human sources include burning processes, such as petrochemical fuel, industrial discharge and moving waste gases. PM2.5 is composed of various chemical materials. After photoreaction, it may create original organic carbon and regenerate organic carbon, elementary carbon, sulfuric acid, nitrate and other ionic matters.

Application Examples

Various types of machines and tools

NC/CNC lathes, multi-purpose lathes, machining centers, NC milling cutters, milling cutters, gear hobbing machines, grinding machines, automatic lathes, drill presses, broaching machines, transfer machines and gun drills.

Molding machines

Die-casting machines, injection molding machines (resins) and large presses.

Additional applications

Molding equipment, quenching machines, induction shrink fit equipment, rolling mills, rolling machines, header units, nut formers, lens chamfering, lens grinding, ceramic processing, glass processing, washer units, coating equipment, air blowers for food, pharmaceutical and cosmetic products.

THE FUTURE OF OIL MIST FILTRATION IS HERE



AOF is specifically designed for machine tools and developed for the elimination of mist, smoke and odor, typical of wet machining operations in metal cutting applications.

FEATURES

- Patented conical filter technology.
- Large selection of capacities.
- The AOF series has a complete line of dedicated accessories for installation on machine tools.
- To eliminate odor and VOC, the filter cells can be regenerated simply by replacing the carbon.
- Requires far less maintenance or filter replacements than existing technology.
- Price competitive with foreign manufacturers.
- Its clogging is monitored with a pressure gauge.
- Filter life is about 1 to 3 years.
- Filtration Module: HEPA removal efficiency eliminates dry smoke, typical of certain applications where straight oil is utilized.
- CARBON Filtration Module: activated carbon filtration (Optional).
- Easy-to-Read Gauge: Indicates normal operation and when filter elements need maintenance.



■ LED lamp indication

Quality Guarantee

- Designed in Europe. Manufactured, tested and assembled in Taiwan.
- The guaranteed level of efficiency is **99%~99.97%** MPPS according to E12/HEPA.
- Electrical motors meet current efficiency standards EISA 2007 / IE3 and are available in: 220V / 380V. (Special voltages are available upon request)

Services

- The presence of AOF Filtration Systems in the market is not limited to the supply of filtration units. Upon request, we can provide a complete consulting service related to the evaluation of air quality in the workplace.

AOF'S CUTTING-EDGE TECHNOLOGY

Integrated with Several Patented Technologies

AOF has applied advanced air-purified technology to develop the high performance oil mist air cleaner, which is excellent for filtrating oil mist, haze, aerosol and smoke. The oil and air separation design follows the European standard. The oil mist air cleaner integrates many innovative designs and provides the best possible oil mist filtration and collection effect.

99%~99.97% Filtrating Efficiency Surpasses European Environmental Protection Standard

AOF oil mist air cleaner features higher air flow rate, greater temperature resistance as well as better acid/alkali resistance. Its filtrating efficiency reaches 99%~99.97%. In addition, an actual environmental protection compliance test indicates that it can achieve E11.E12, surpassing the European standard of F8.F9. It also strengthens the fact that AOF oil mist air cleaner is unique in terms of efficiency and zero pollution.

1 1st - Stage Pre-Filtering System



The oil mist airstream initially collides with the fish scale profile, coalescing the mist into larger droplets. Then, through a wind shear effect with the 70-degree, self-draining mesh filter, additional smoke and particles greater than 2 microns (2 μm) are captured.



Patented 70-degree conical mesh filter featuring an innovative fish scale profile on the leading edge and a synthetic mesh overlay. A built-in handle makes maintenance easy on this washable element.

2 2nd - Stage Airflow

The efficient centrifugal impeller fan located in the 2nd chamber provides highly efficient system airflow at low running noise and continues the running process.



3 3rd - Stage After-Filter

Finishes the air purification to a **99.97%** filtering efficiency by capturing all particles before releasing the purified air back into the plant.



UNIQUE DESIGNS IN ONE UNIT EXPERIENCE UNPRECEDENTED PERFORMANCE

Description of After-Filters

Filtrating area increased by 20% (Compared to general round after-filter)

- Oil capture efficiency: 99~99.97%
- Filtrating accuracy: 0.01 μm
- The AOF purification equipment works with the principle of air excitation → mitigation → filtration. This may effectively enhance the settlement speed of oil mist, smoke and haze, while exhibiting high efficiency and high accuracy features.

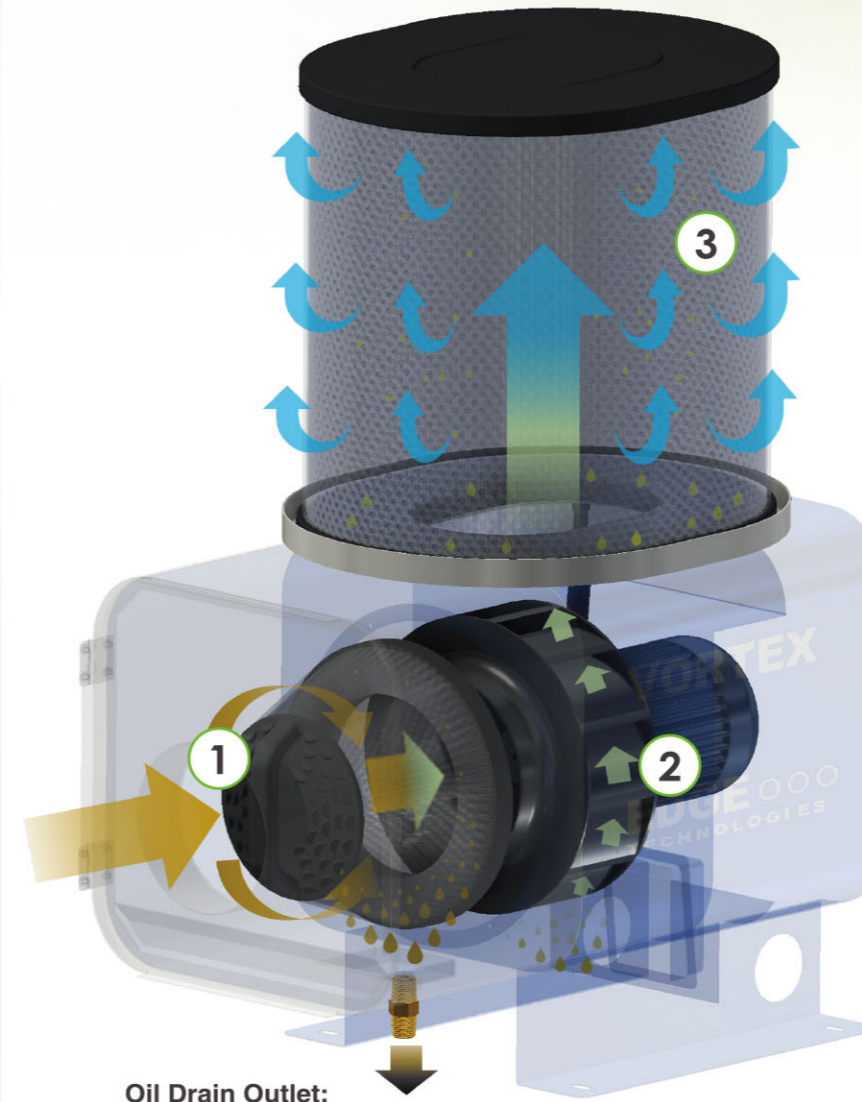

Oil Drain Outlet:

Precipitated droplets are collected and returned to the coolant tank.



(Custom-made)

PL series (Long-acting type)

- For oil-based coolant
- Filtering oil mist, particle ≥ 0.02 μm
- 600 mm long
- Filtering area increased by 200% (Compared to P series).



S series (Standard type)

- For soluble coolant
- Filtering water mist, particle ≥ 0.5 μm
- 300 mm long



P series (Practical type)

- For oil-based coolant
- Filtering oil mist, particle ≥ 0.03 μm
- 400 mm long



(Custom-made)

PM series (High efficiency type)

- For toxicant oil-based coolant
- Filtering oil mist, particle ≥ 0.01 μm
- 600 mm long
- With active carbon ingredients.

SPECIFICATIONS

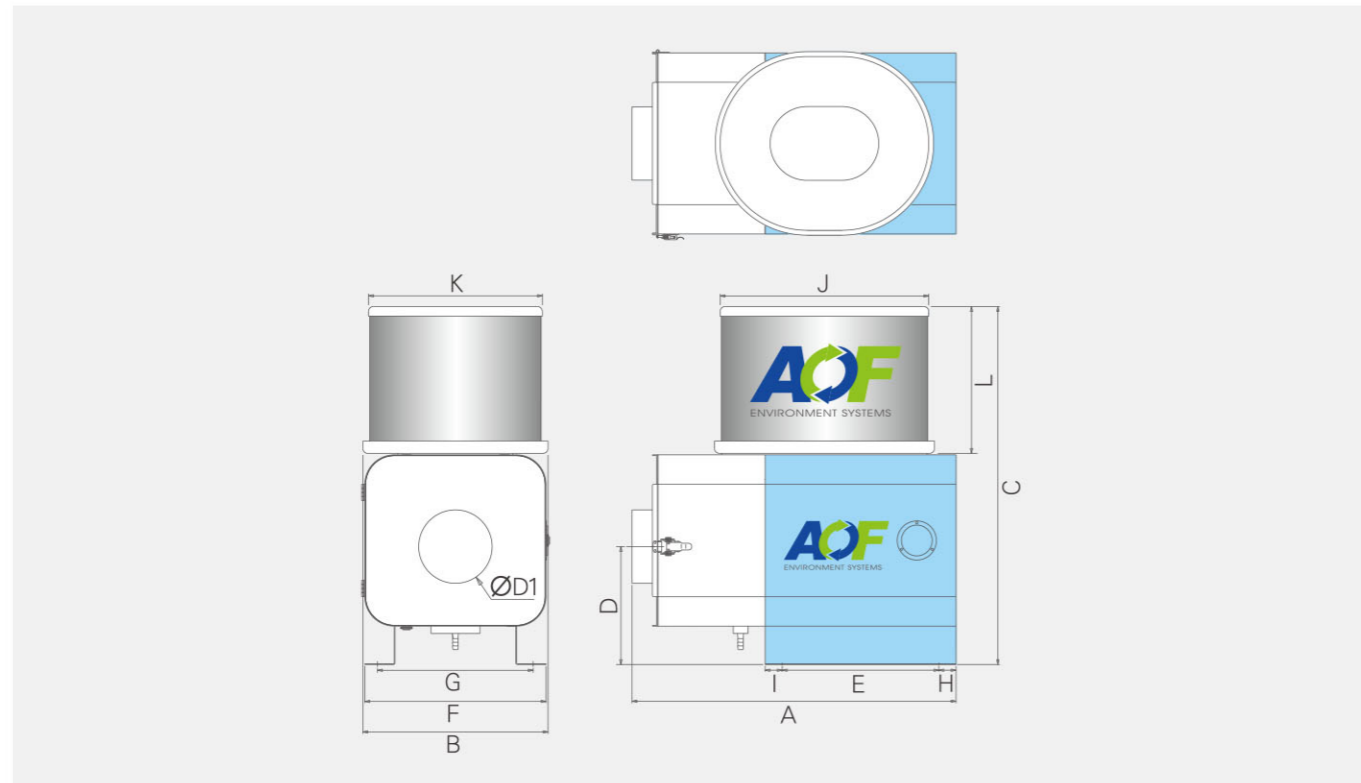

Model	Power Source	Motor	Air Flow Rate (m ³ /min) (50Hz / 60Hz)	Static Pressure (kPa) (50Hz / 60Hz)	Noise Value db (A) (50Hz / 60Hz)	Filtering Effect	Weight (Kg)	Air Inlet Port	Applicable Space
AF-10P	3 PHASE AC220V or AC380V 50/60HZ	0.2 KW	11 / 13.5	0.65 / 1.05	65 / 68	99.97% EU E12 Standard	42	Ø150	< 6m ³
AF-20P		0.4 KW	18 / 20.5	0.88 / 1.38	69 / 73		47	Ø150	< 12m ³
AF-30P		0.75 KW	29 / 32.5	1.15 / 1.65	70 / 74		65	Ø200	< 24m ³
AF-40PL		1.15 KW	40 / 48.5	1.45 / 1.95	71 / 75		80	Ø250	< 32m ³

Model	A	B	C	D	D1	E	F	G	H	I	J	K	L
AF-10P	615	379	831	236	148	300	335	283	25	25	426	355	413
AF-20P	652	379	851	234	148	320	350	298	25	25	426	355	413
AF-30P	765	432	908	299	200	388	420	368	25	25	492	408	413
AF-40PL	792	490	1153	316	250	388	480	428	33.5	33.5	540	430	613

■ Above figures are tested with the models of P / PL series.

DESCRIPTION OF PARTS

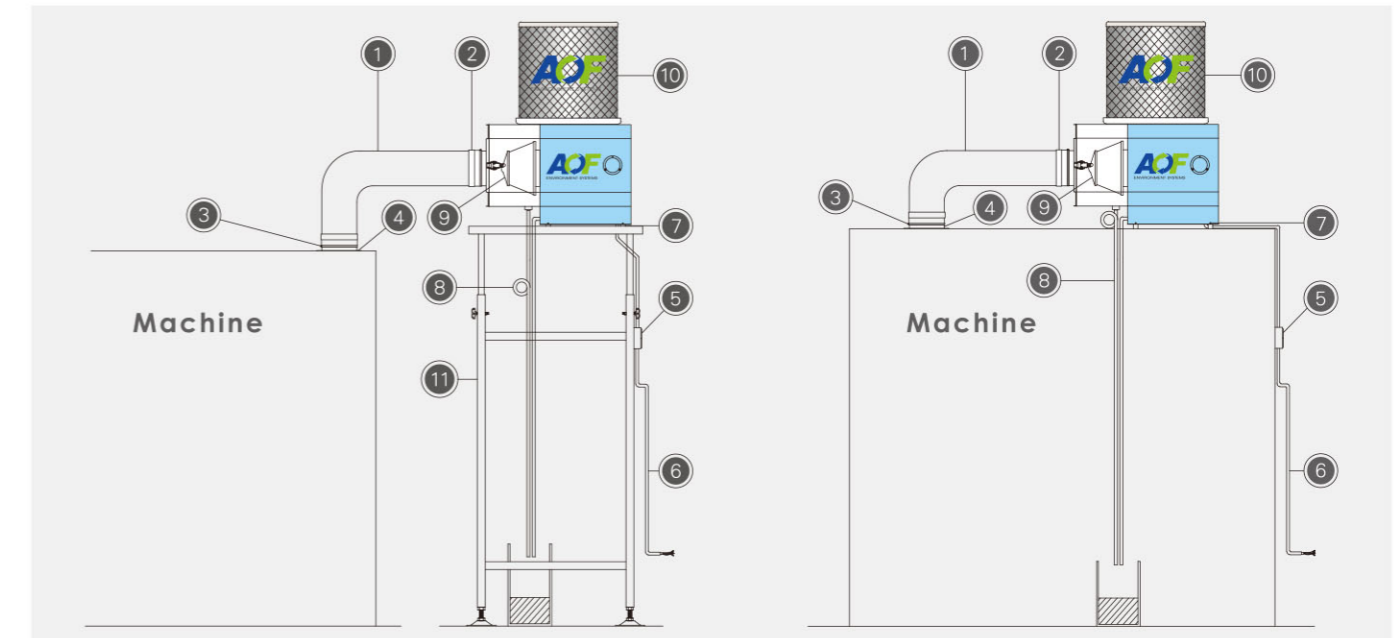

No.	Part Description	Model	AF-10	AF-20	AF-30	AF-40
1	Flexible hose (Standard accessories x 1)	Type	TW-H150	TW-H150	TW-H200	TW-H250
		Outside dia.	Ø150	Ø150	Ø200	Ø250
2	Sleeve for flexible hose (Standard accessories x 2)	Type	JP-HC150	JP-HC150	JP-HC200	JP-HC250
		Outside dia.	Ø150	Ø150	Ø200	Ø250
3	Flexible hose clamp (Standard accessories x 2)	Type	BP-HB165	BP-HB165	BP-HB215	BP-HB265
		Outside dia.	Ø150	Ø150	Ø200	Ø250
4	Air inlet adaptor (Standard accessories x 1)	Type	PM-150	PM-150	PM-200	PM-250
		Outside dia.	Ø150	Ø150	Ø200	Ø250
5	Power switch (Standard accessories x 1)	Type	E0-220/380/415			
		Outside dia.	158 × 85 × 105mm			
6	Oil resistant cable (Standard accessories 3.3M x 1)	Type	CA-1.25mm ² × 4C			
		Outside dia.	1.25mm ² × 4C			
7	Anti-vibration mount (Standard accessories x 4)	Type	WL-M8 × 20L		WL-M10 × 15L	
		Outside dia.	M8-20L Ø30 × 30L		M10-15L Ø50 × 50L	
8	Oil drain hose (Standard accessories 3M x 1)	Type	OH-R12			
		Outside dia.	Ø12			
9	Pre-filtering system (Standard accessories x 1)	Type	FC-250-O	FC-250-O	FC-300-O	FC-300-O
		Outside dia.	Ø250	Ø250	Ø300	Ø300
10	After-filter (Standard accessories x 1)	Type	S: Standard type, 300mm long P: Practical type, 400mm long PL: Long-acting type, 600mm long PM: High efficiency type, 600mm long			
		Type	PV-SU-1800			
11	Telescopic stand (Choice of a stand or castors) (Optional accessories)	Type	PV-SU-1800			
		Height: 1100mm, Extension: 1800mm				